



## **Acousto-Optic Modulator Driver**

**Including: Basic Modulator Alignment**

## **Instruction Manual**

**RFA080-2-3 – Dual Channel Analog Modulation**



## 1. GENERAL

The RFA080-2-3 dual Analog Driver is a fixed frequency RF power source specifically designed for use with Isomet acousto-optic dual channel modulators. The driver features a single 80MHz crystal oscillator and this is a common frequency source to both channels. Each output channel has an independent analogue modulation input and separate power adjuster.

Figure 2 is a block diagram of the driver. The center frequency of the driver is determined by the free-running quartz-crystal oscillator. This frequency is accurate to within  $\pm 25$ ppm. The oscillator is not temperature stabilized.

Each channel uses a high-frequency, diode ring mixer to modulate the RF carrier according to the signal applied to the respective MOD input; A or B. An input swing of 10 volt peak will result in 100% depth of amplitude modulation. **The video input level must not exceed  $\pm 12$  volts**

The mixer outputs are each applied to a MMIC pre-amplifier stage. This also serves to isolate the Oscillator and Mixer from the final power amplifier stage. The peak output power for each channel is set by the Power adjust potentiometers A and B .

The final stage is a DMOS FET based power amplifier. The two amplifiers are designed to operate at full rated power into a  $50\Omega$  load with 100% duty cycle.

Figure 3 illustrates the principal waveforms of the Driver.

Water cooled base is provided. The mounting face temperature must not exceed  $70^{\circ}\text{C}$ .

**SERIOUS DAMAGE TO THE AMPLIFIER MAY RESULT IF THE TEMPERATURE EXCEEDS  $70^{\circ}\text{C}$ .  
SERIOUS DAMAGE TO THE AMPLIFIER MAY ALSO RESULT IF THE RF OUTPUT CONNECTOR  
IS OPERATED OPEN-CIRCUITED OR SHORT-CIRCUITED.**

The required supply voltage is +24 / 28Vdc at a current drain of approximately 2A . The external power source should be regulated to  $\pm 2\%$  and the power supply ripple voltage should be less than 25mV for best results.

## 2. ANALOG MODULATION

To intensity modulate a laser beam in an acousto-optic modulator requires that the input RF carrier voltage (power) be varied according to the video or baseband information. From the viewpoint of intensity modulation, the deflection efficiency equation is normalized as:

$$i_1 = \sin^2(kE_{RF})$$

where  $i_1$  is the instantaneous intensity in the first order diffracted beam and  $E_{RF}$  is the instantaneous RF envelop voltage across the matched transducer.

Figure 4 shows the intensity vs. RF envelop voltage transfer function of the acousto-optic modulator in normalized units with the typical waveforms superimposed. It will be noted that the driving RF waveform is a double-sideband amplitude-modulated carrier. In effect, the acousto-optic interaction demodulates the RF carrier, transforming the modulation envelop (baseband signal) into intensity variation of the first order diffracted laser beam.



### 3. INSTALLATION AND ADJUSTMENT

- 3.1 Install the Driver on a heat sink as shown in figure 1. Connect cooling water.
- 3.2 With no d-c power applied, connect the positive (+) DC to the center terminal of the feed-thru terminal as shown in figure 1. Connect the 0V or ground connection to the earth tab.  
DO NOT APPLY POWER.

**DO NOT EXCEED +28Vdc or apply reverse polarity.**

- 3.3 Connect the RF output SMA jacks to the two SMA inputs of the dual channel acousto-optic modulator (or 50 $\Omega$  RF load, if it is desired to measure the modulator RF output power).
- 3.4 Connect a 50 ohm signal source to the Modulation inputs on the 15way connector
  - Amplitude modulation 'A', 0 - 10V, pin 7
  - Amplitude modulation 'B', 0 – 10V, pin 5
  - 0V return, pin 14
- 3.4.b Connect a TTL signal source to the GATE input on the 15way connector
  - TTL Gate > 2.7V = RF On, pin 8
  - 0V return, pin 15
- 3.5 Adjustment of the RF output power is best done with Driver connected to the acousto-optic modulator. The Driver maximum output powers are factory preset to a nominal level of 2.0Watt at each output.

**The optimum RF power level required for the modulator to produce maximum first order intensity will be different at various laser wavelengths. Applying RF power in excess of this optimum level will cause a decrease in first order intensity (a false indication of insufficient RF power ) and make accurate Bragg alignment difficult. It is therefore recommended that initial alignment be performed at a low RF power level.**

3.6 The PWR ADJ pot is a single-turn type. Minimum power is fully anti-clockwise (CCW).

To start alignment:

Rotate the PWR ADJ potentiometer fully CCW then CW approx' 1/3 turns.

3.7 Apply, + 24V, or +28V DC power to the driver as appropriate for the model.

3.8 Apply +10.0V dc input level to the desired Modulation input.

3.8 Apply TTL high to the GATE input.

3.9 Observe the diffracted first-order output from the acousto-optic modulator and the undeflected zeroth order beam. Adjust the Bragg angle (rotate the modulator) to maximise first order beam intensity.

Note: the diffraction efficiency may not exceed 20-30% at this point in the alignment procedure.

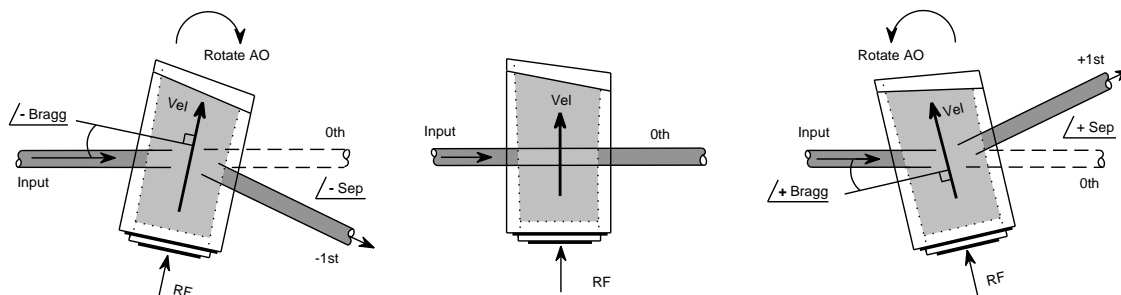

For most AO devices, Bragg angle rotation can be +ve or -ve and the laser can be input to either aperture face.

3.10 After the Bragg angle has been optimised, slowly increase the RF power by rotating the PWR ADJ pot A or B clockwise depending on beam/AO channel until maximum first order intensity is obtained. This peaked RF drive level is termed the saturation power;  $P_{sat}$ . For applications using a well focussed input beam into the AOM, the correctly adjusted Bragg angle condition is indicated when the zero order shows a characteristic dark line through the middle of the beam at or near the  $P_{sat}$  drive level.

The dual AOM and driver are now configured for analog modulation

## Connection Summary

1.0

### 15 way 'D' Type Control Connection

<u>Signal</u> (see notes)	<u>Type</u>	<u>Pin out connection</u>
<u>GATE</u> Digital Gate ** TTL high ( $2.7V < V < 5.0V$ ) = ON TTL low ( $0.0V < V < 0.8V$ ) or nc = OFF [Input current 4.8mA at 3V]	Input	Signal pin 8 Return pin 15
<u>MODULATION</u>		
Channel A Modulation, proportional $< 0.4V$ (off) to $10.0V$ (on) [Input current 4.0mA at 10V]	Input	Signal pin 7 Return pin 14
Channel B Modulation, proportional $< 0.4V$ (off) to $10.0V$ (on) [Input current 4.0mA at 10V]	Input	Signal pin 5 Return pin 12
'Interlock Valid' monitor Open Drain logic, Low = OK	Output	Signal pin 2 Return pin 10

**Maximum applied voltage (via external pull up resistor) = 5.5V**

[Maximum current = 10mA]

### Input connections

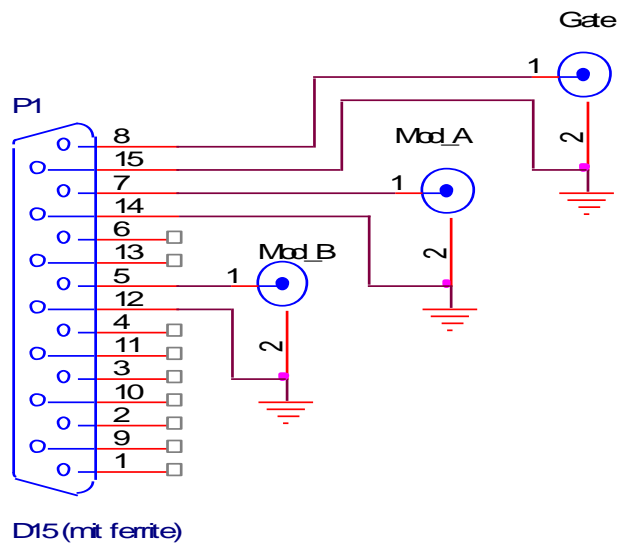



#### 4. MAINTENANCE

##### 4.1 Cleaning

It is of utmost importance that the optical apertures of the deflector optical head be kept clean and free of contamination. When the device is not in use, the apertures may be protected by a covering of masking tape. When in use, frequently clean the apertures with a pressurized jet of filtered, dry air.

It will probably be necessary in time to wipe the coated window surfaces of atmospherically deposited films. Although the coatings are hard and durable, care must be taken to avoid gouging of the surface and residue of the cleaning solution. It is suggested that the coatings be wiped with a soft ball of brushed (short fibres removed) cotton, slightly moistened with clean alcohol. Before the alcohol has had time to dry on the surface, wipe again with dry cotton in a smooth, continuous stroke. Examine the surface for residue and, if necessary, repeat the cleaning.

##### 4.2 Troubleshooting

No troubleshooting procedures are proposed other than a check of alignment and operating procedure. If difficulties arise, take note of the symptoms and contact the manufacturer.

##### 4.3 Repairs

In the event of deflector malfunction, discontinue operation and immediately contact the manufacturer or his representative. Due to the high sensitive of tuning procedures and the possible damage which may result, no user repairs are allowed. Evidence that an attempt has been made to open the optical head will void the manufacturer's warranty.

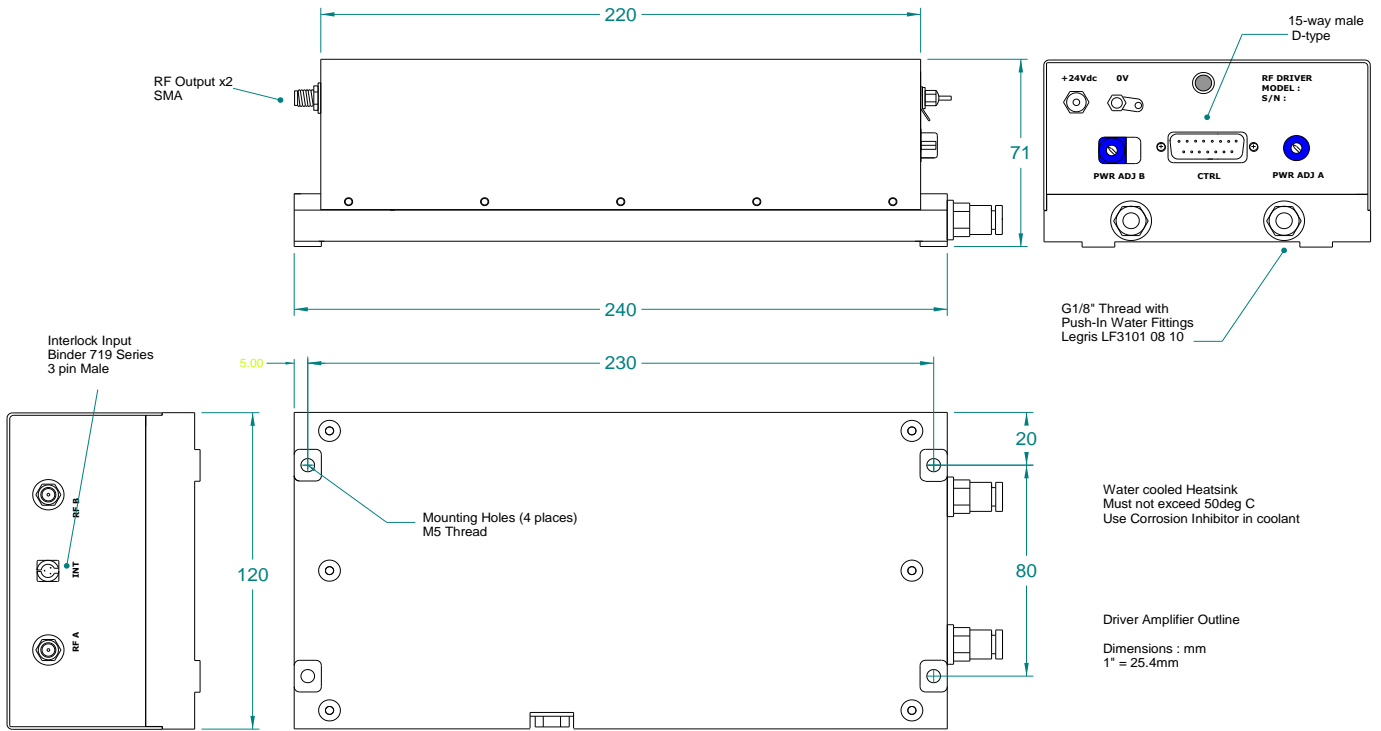

Figure 1: Driver Installation

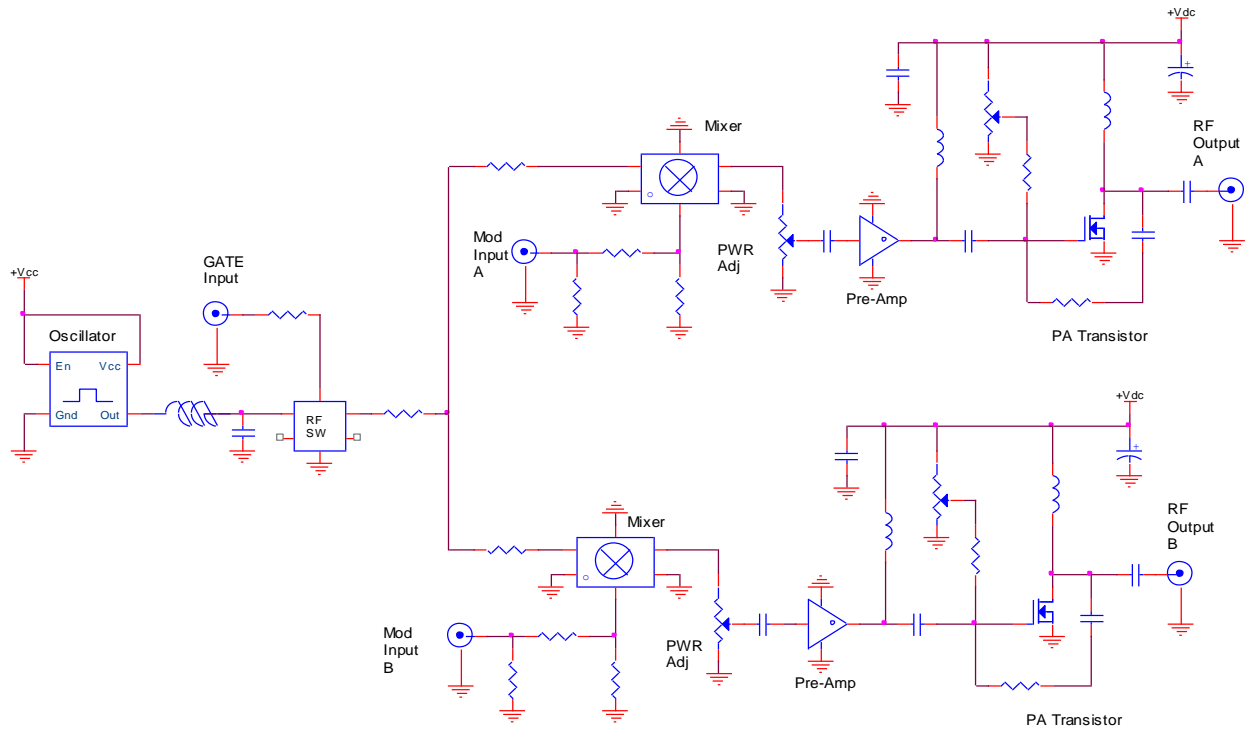
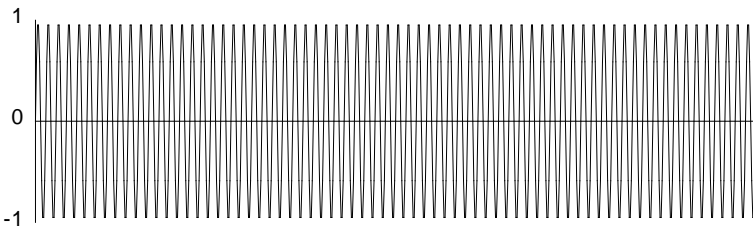
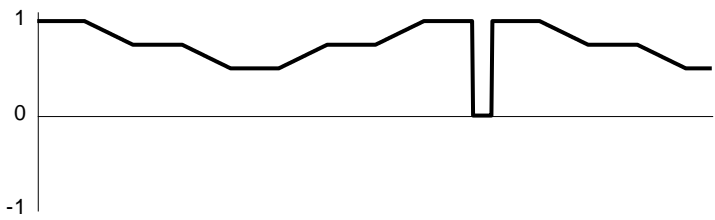

Figure 2: Driver Block Diagram





RF Carrier



Video Input

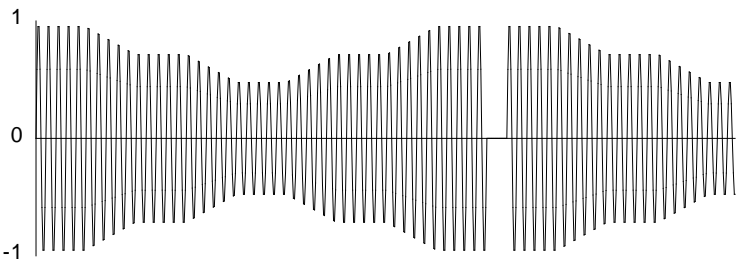

Modulated RF

Figure 3: Typical Analog Modulation Waveforms

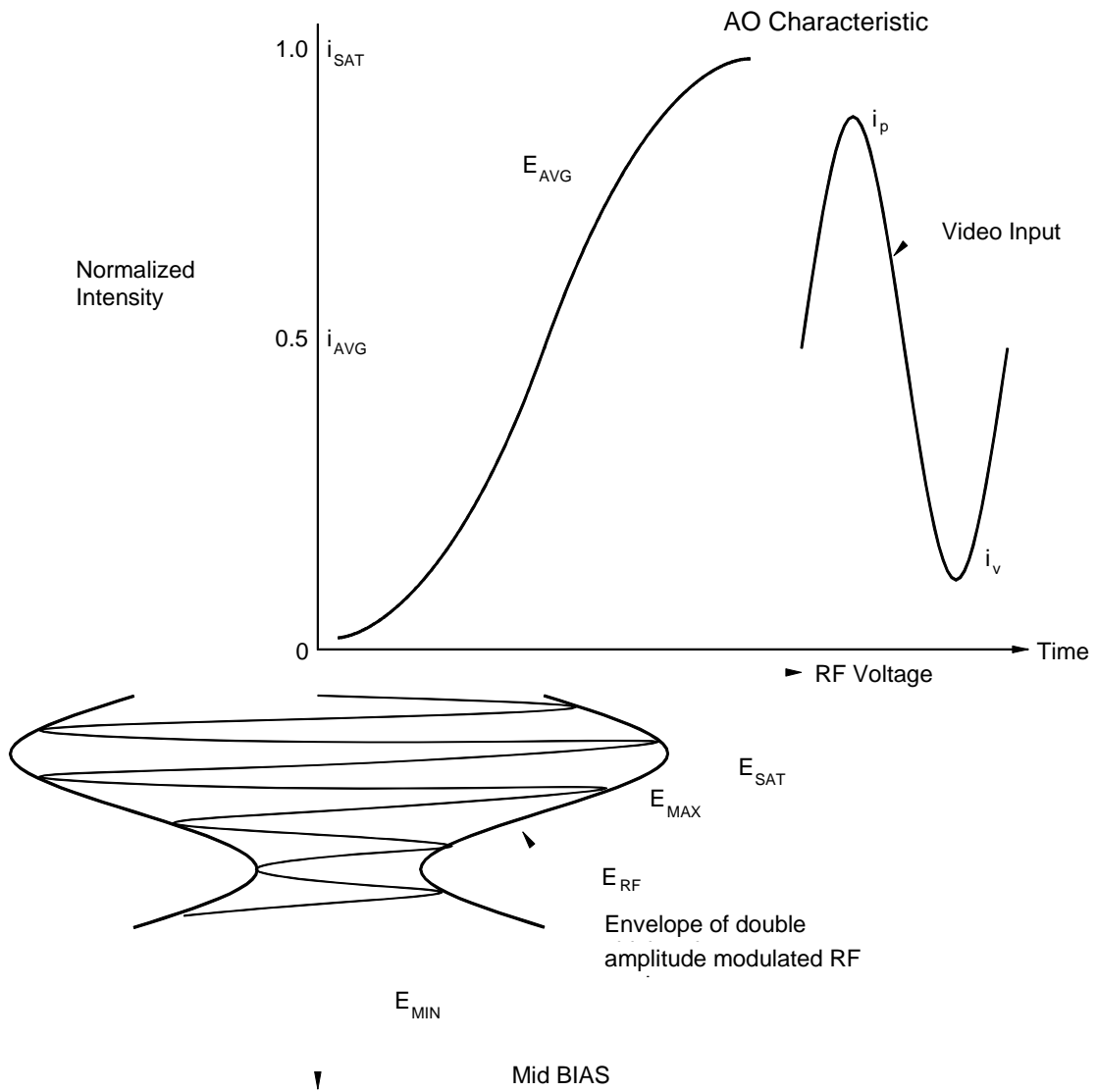
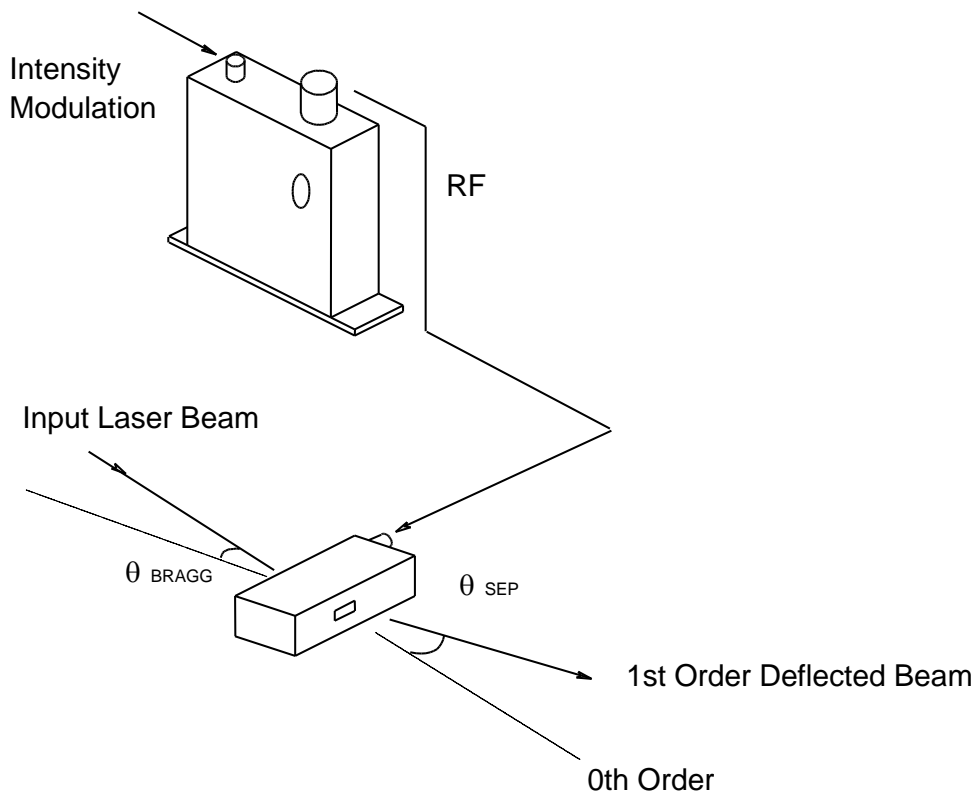

Figure 4.  
Intensity vs. RF Envelope Voltage Transfer

Schematic for an AO modulator with analogue driver



The input Bragg angle, relative to a normal to the optical surface and in the plane of deflection is :

$$\theta_{BRAGG} = \frac{\lambda \cdot f_c}{2 \cdot v}$$

The separation angle between the zeroth order and the first order outputs is :

$$\theta_{SEP} = \frac{\lambda \cdot f_c}{v}$$

Optical rise time for a Gaussian input beam is approximated by :

$$t_r = \frac{0.65 \cdot d}{v}$$

where :  $\lambda$  = wavelength

$f_c$  = centre frequency

$v$  = acoustic velocity of AO interaction material = 4.21mm/usec (TeO<sub>2</sub>)  
 = 3.63mm/usec (PbMoO<sub>4</sub>)  
 = 5.96mm/usec (Fused Si)

$d = 1/e^2$  beam diameter

Figure 5: Modulation System